

LET'S MAKE
ROOM FOR
PEOPLE

PRESSALIT®



New

INDIVO Pack

Making Accessibility a Natural Part of Everyday Life

Accessibility is the key to an inclusive society where everyone – regardless of physical abilities – can participate in social activities, education, and daily tasks. Height-adjustable tables make a significant difference in the daily lives of people with disabilities and enhance their independence.

Make Accessibility Simple - with Ease

For wheelchair users, fixed installations in kitchens, schools, and public spaces can be a barrier. However, with the INDIVO Pack from Pressalit, accessibility becomes a simple and flexible solution. Our innovative package solution makes it easy to order the right components to ensure a quick trouble-free installation – helping you create a more accessible and inclusive environment in no time.

- Easy to order – one pack contains all you need (excl. countertop)
- Easy to install and adjust to size on site
- Work surfaces with or without sinks and stoves can be easily fitted on INDIVO frames (these items are not included in the pack).



Product Overview



Mounting Video

Tailored Flexibility - Anywhere

With the INDIVO Pack, you can easily create the perfect workstation. It comes in three sizes – small, medium, and large – and two weight categories, 220 lbs and 330 lbs, so you can choose the size that best fits your needs. Adjust the height with a single press of a button and experience ultimate flexibility in a wide range of environments:

- **Private Homes** – Create an ergonomic and user-friendly kitchen where everyone can participate, regardless of age or mobility.
- **Schools and Institutions** – Adjustable work surfaces ensure that all students can take part in lessons on equal terms – from school kitchens to science labs.
- **Care Homes** – A flexible kitchen solution that supports various needs and makes everyday life easier for both residents and staff.
- **Bars and Restaurants** – Create an inclusive experience for all guests, whether they are standing or seated at the bar.

INDIVO Packs, electric, with 2 lifting columns

Maximum load 220 lbs

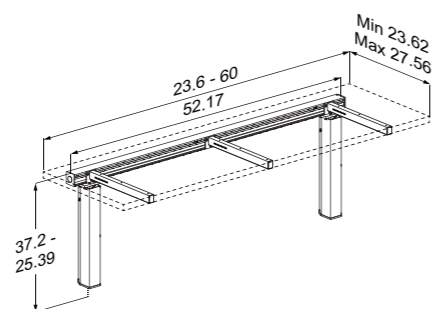

INDIVO Pack Small

RK1860202. For countertop **23.6" - 60"**
Height adjustable 11.8", 25.4" - 37.2"

- 2 INDIVO lifting columns
- 1 Cross brace
- 1 Safety strip, self-adhesive
- 1 Cable tray
- 1 Electrical components kit
- 3 Stability bars for countertop
- 12 Brackets for fitting of fascia

Excl. mounting kit

INDIVO Packs, electric, with 3 lifting columns

Maximum load 330 lbs

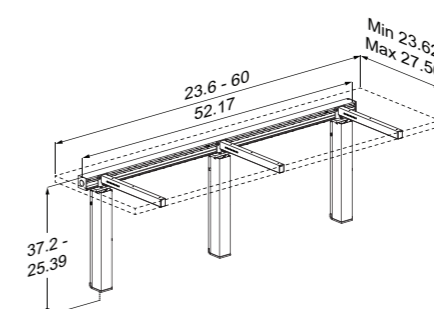

INDIVO Pack Small

RK1880202. For countertop **23.6" - 60"**
Height adjustable 11.8", 25.4" - 37.2"

- 3 INDIVO lifting columns
- 1 Cross brace
- 1 Safety strip, self-adhesive
- 1 Cable tray
- 1 Electrical components kit
- 3 Stability bars for countertop
- 12 Brackets for fitting of fascia

Excl. mounting kit

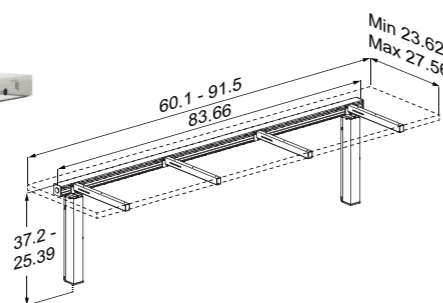

INDIVO Pack Medium

RK1862202. For countertop **60.1" - 91.5"**
Height adjustable 11.8", 25.4" - 37.2"

- 2 INDIVO lifting columns
- 1 Cross brace
- 1 Safety strip, self-adhesive
- 1 Cable tray
- 1 Electrical components kit
- 4 Stability bars for countertop
- 16 Brackets for fitting of fascia

Excl. mounting kit

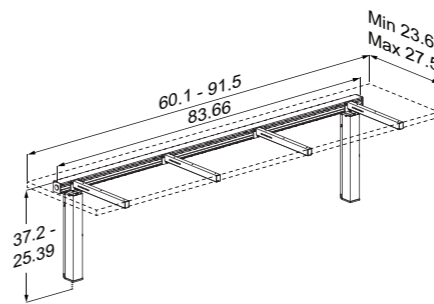

INDIVO Pack Medium

RK1882202. For countertop **60.1" - 91.5"**
Height adjustable 11.8", 25.4" - 37.2"

- 3 INDIVO lifting columns
- 1 Cross brace
- 1 Safety strip, self-adhesive
- 1 Cable tray
- 1 Electrical components kit
- 4 Stability bars for countertop
- 16 Brackets for fitting of fascia

Excl. mounting kit

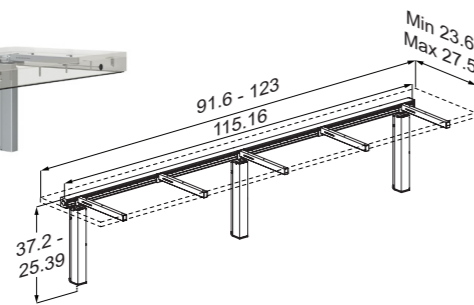

INDIVO Pack Large

RK1864202. For countertop **91.6" - 123"**
Height adjustable 11.8", 25.4" - 37.2"

- 2 INDIVO lifting columns
- 1 Cross brace
- 1 Safety strip, self-adhesive
- 1 Cable tray
- 1 Electrical components kit
- 5 Stability bars for countertop
- 20 Brackets for fitting of fascia

Excl. mounting kit

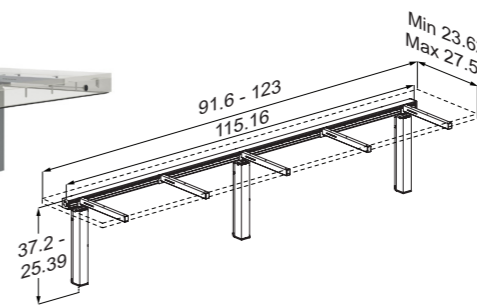

INDIVO Pack Large

RK1884202. For countertop **91.6" - 123"**
Height adjustable 11.8", 25.4" - 37.2"

- 3 INDIVO lifting columns
- 1 Cross brace
- 1 Safety strip, self-adhesive
- 1 Cable tray
- 1 Electrical components kit
- 5 Stability bars for countertop
- 20 Brackets for fitting of fascia

Excl. mounting kit

LET'S MAKE ROOM FOR PEOPLE

PRESSALIT®



PREMIUM BATHROOM SOLUTIONS SINCE 1954

Pressalit A/S is a Danish privately owned company with production facilities in Ry, Denmark. Since 1954, we have been designing and producing toilet seats of the highest quality. And since 1975, Pressalit has also been developing accessible bathrooms and height adjustable kitchens for people with reduced mobility. This has made us one of the world's leading manufacturers of premium bathroom solutions. High quality, flawless design and reliable functionality are the core features of our wide range of products.

PRESSALIT SUPPORTS UNITED NATIONS GLOBAL GOALS



WE SUPPORT

Pressalit A/S, Pressalitsej 1, 8680 Ry, Denmark,
T: +45 8788 8788, F: +45 8788 8789
pressalit@pressalit.com

Pressalit.com



Pressalit's Environmental and Quality Management Systems are certified by LRQA



MADE IN DENMARK



Subject to changes in the product range, technical changes and printing errors.